



# SCHAEFF

A **YANMAR** BRAND

# COMPACT WHEEL LOADER



Operating weight	4 900 kg
Net Power	46,2 kw (63 HP)
Bucket capacity	0,8 – 1,2 m <sup>3</sup>
Steering	Articulated steering

## TL80

# ABSOLUTE RELIABILITY



## STRAIGHT AND RIGID ARTICULATION

For better reliability, for better stability. The wheels forward and backward follow the same way. No damage to the lawns, or pavements. Short turning radius and optimal positioning of pallet forks. Less wear on tires.



## EASY TO USE

The V80 is fitted with various equipment which enable precise, comfortable and productive control of the machine: Smart control, Fingertip control and multi-function joysticks offer optimal handling to the operator for a productive day work.



## REAR OSCILLATING AXLE

Improved operator comfort, increased machine stability, longer life. The stability of the machine is optimized when using the bucket and forks.



## PARALLEL KINEMATICS

Thanks to its parallel kinematic system, the V80 takes loads quickly and precisely without having to constantly adapt the load angle.

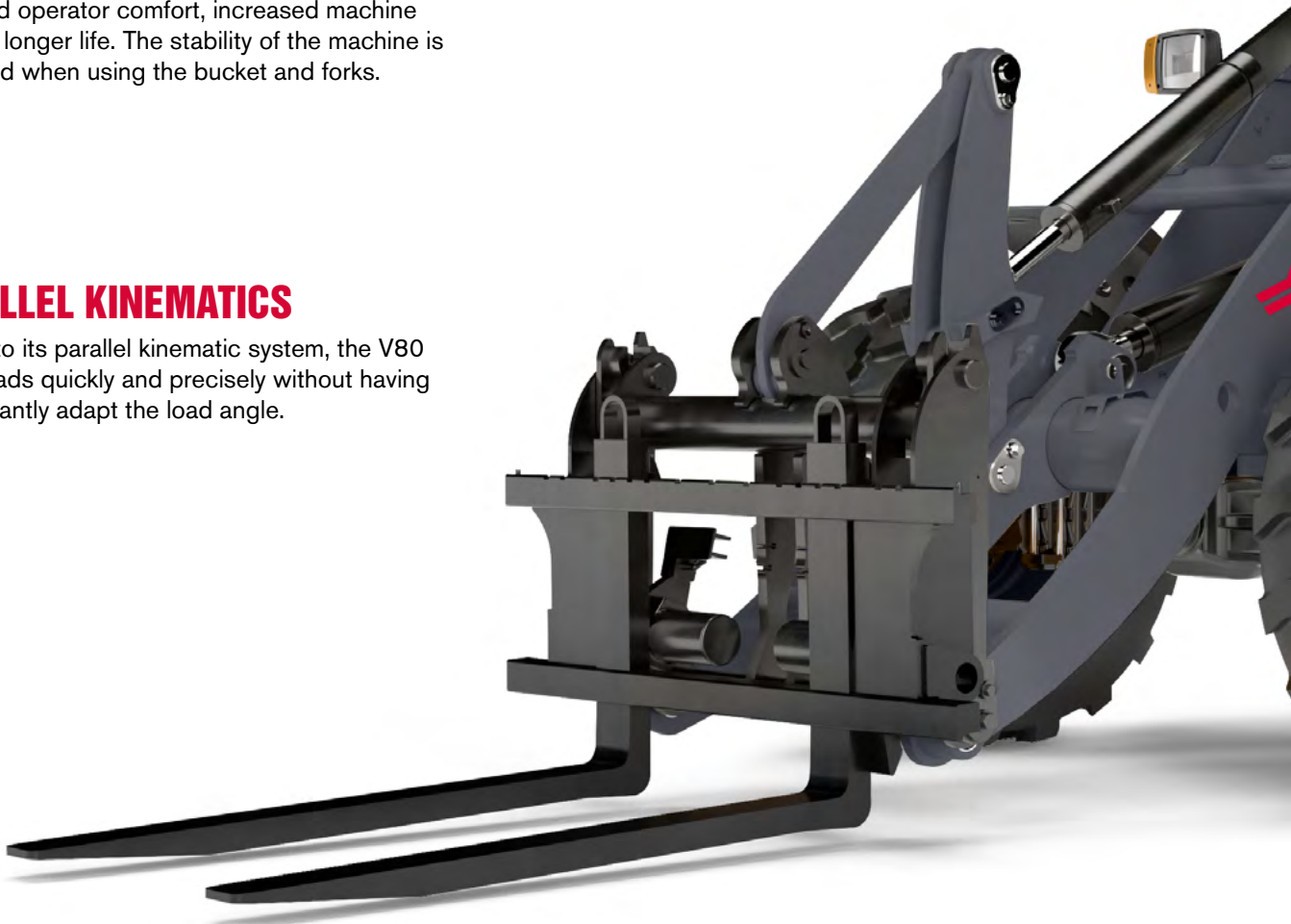



## COMFORTABLE CABIN

Designed to ensure maximum comfort and productivity for the operator. The performance enhancing environment provides a very pleasant working atmosphere. The control system for the machine uses innovative technology. The machine remains easy to handle, even when used in challenging conditions. This helps driver and machine deliver high productivity.



## MOTOR

Complies with EU Phase V / EPA Tier 4, guaranteeing reduced fuel consumption and emissions. The cross-mounted motor allows easy access for maintenance and acts as a counterweight.



## HYDRAULIC QUICK-HITCH SYSTEM

The quick-hitch system allows the accessories to be easily changed from the cabin with two controls.



# LOADER CONCEPT

## ARTICULATED STEERING WITH OSCILLATING REAR AXLE

When used at a densely built-up location or construction sites with limited space, the articulated steering delivers great maneuverability with its 40° steering angle.

The articulated steering also allows the bucket to approach the load in a straight line, even at the maximum steering angle. This affords the operator greater flexibility in terms of picking up pallets or setting down loads. The oscillating rear axle has a wide slewing angle of 10°, keeping all 4 wheels in contact with the ground at all times, even when working on uneven ground. The operator also sits parallel to the work attachment at all times. Only the rear axle oscillates – unlike other manufacturers, where the whole of the rear end oscillates. This means the weight of the machine is always moving in the same direction as the bucket, which in turn increases the pressure on the ground when backing up.

## DIMENSIONS

The V80 has very compact dimensions in all aspects: height (<2,7 m), width, length and turning radius. These compact dimensions contribute to the high maneuverability of Yanmar wheel loaders.





# LIFTING FRAME

## PARALLEL KINEMATICS

The parallel kinematics system allows you to lift a load quickly and precisely without constantly having to adjust the loading angle.

While the kinematics system take care of the stroke angle, the operator is free to concentrate on where exactly to set down the load. The parallel kinematics system optimise work cycles when loading and unloading the second row on a truck. The clever design ensures the tilt control lever does not collide with the body of the truck.

## HYDRAULIC QUICK HITCH

Replace tools quickly and easily from the cabine using the quick-hitch system thanks to two-handed operation. It is easy and very safe to operate and allows quick and smooth change of attachments.

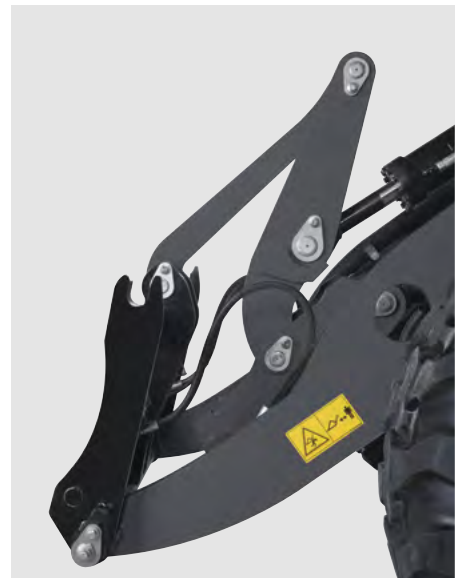
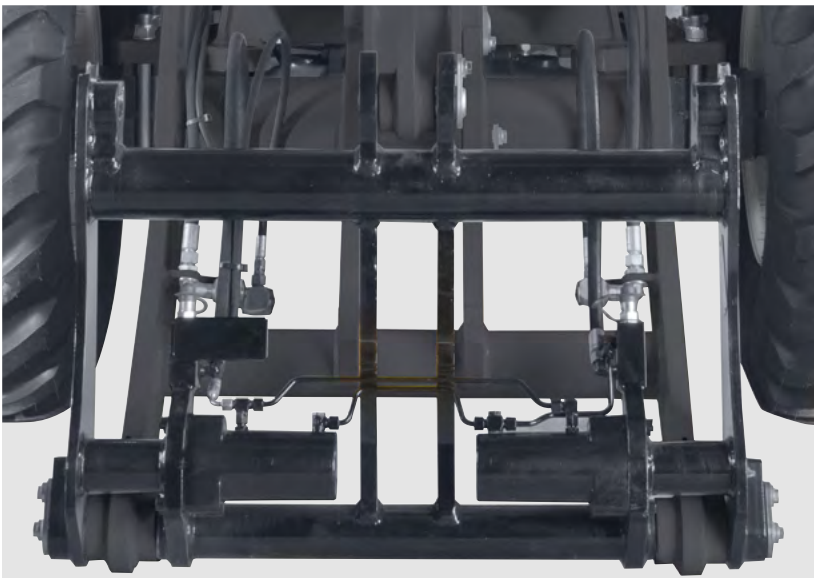

# POWERLINE

## ENGINE

The V80 is fitted with a powerful engine which delivers results in terms of operation and environmental protection. Fewer emissions, more power. Engine: EU Stage V, EPA TIER IV. Adopting European and American emission levels ensure a significant reduction in particulate emissions compared with previous levels – from 0.4 to 0.025 g/kWh.

## TAKE ADVANTAGE OF THE NEW ENGINE TECHNOLOGY

- ▶ Lower fuel consumption really pays off. The machine is delivered with a diesel particulate filter as standard. This saves on servicing costs.
- ▶ Fresh air: pollutants in the emissions from the V80 are reduced by up to 90%. Significantly fewer particulate are emitted thanks to the advanced exhaust after-treatment. This is achieved by means of improved combustion and injection systems and a diesel oxidation catalyst (DOC).



- ▶ Drive characteristics have been optimised for the new engine to deliver performance and meet regulations.

## HYDROSTATIC TRANSMISSION

Hydrostatic high-pressure transmission, maximum productivity thanks to hydrostatic drive technology – smooth power development without interruption of traction.

## WORKING HYDRAULIC

The working hydraulic (3rd Section) work completely independently of the hydraulics for transmission. 3rd Section for operation of hydraulic quick coupler and common work tools.

Additional control circuit (4th Section) for operation of special attachments, which requires hydraulic oil flow (optional). The 4th Section is also available with High Flow function (optional).

## AUTOMATIC DIFFERENTIAL LOCK

The V80 fits with permanent all-wheel drive and automatic self-locking differentials on the front and rear axles (35% locking effect). Both provide enhanced traction when traveling in a straight line and turning corners – perfect for bucket loading.

## TRAVEL RIDE CONTROL\*

The travel ride control function induces a suspension effect in the boom cylinder thanks to an accumulator. This system improves the drivability of the loader when transporting loads on uneven ground or driving at high travel speed. This feature improves drastically the operator comfort.

\*Option for V80

## TRACTIVE FORCE

The hydrostatic transmission is characterized by its high power and smooth adjustment. This results for the operator in high rim pull for effective pushing or digging and good travel performance even on steep inclines.



# SMART CONTROL

Smart Control is the Yanmar operating system for compact wheel loaders. It has never been easier to match a construction machine precisely to the driver and application. Numerous controls have also been redesigned and rearranged for quicker operation and improved machine monitoring. The 3.5" display shows machinery and engine data. The modern menu guide is similar to current smartphones. The windscreen, which domes inwards, minimizes the mirror effect.

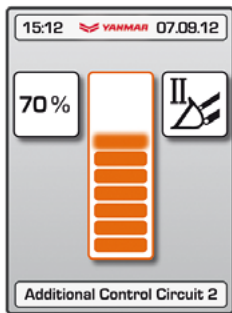

Electrical proportional adjustment of the hydraulic performance of the 3rd circuit.

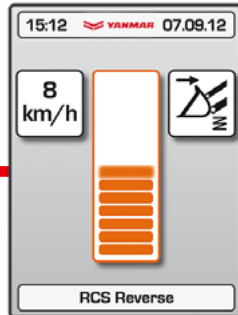

Activation of the motion control function at specific speed.

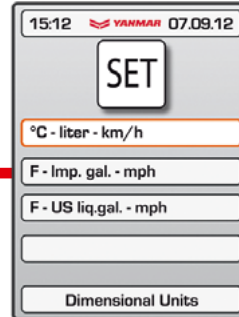

Choice of units of measurement by country.



## What this means for you:

- ▶ Intuitive operation that is easy to set for each individual driver
- ▶ 3rd & 4th electric proportional hydraulic control circuit for operating work attachments
- ▶ New display design to enable easy machine monitoring
- ▶ Keypad with extra-large keys for easy operation



## INSTRUMENTATION

An additional Keypad allows quick adjustment of a main installation.



## ADJUSTABLE STEERING COLUMN

The adjustable steering column is part of the standard equipment of the machine. It improves the operator comfort and makes it easier to enter and exit the cabin from both sides.

# OPERATOR STATION

Designed with driver comfort and productivity in mind, the cabine features noise and vibration damping and is ROPS/FOPS- approved.



## ALL-AROUND VISIBILITY

Visibility is optimized through big windows. The optimal visibility leads to greater safety on jobsites. Front visibility is optimum on the attachment for faster and safer operation.

## SECOND DOOR

- ▶ Optimal cabine ventilation
- ▶ Communication possible on both sides
- ▶ Cab easy to clean
- ▶ Improved visibility, even at ground level



## COMFORTABLE & ADJUSTABLE SEAT

Our standard seat with hydraulic suspension, adjustable in position and weight, makes it more comfortable for the driver.

## PRECISE FINGERTIP CONTROL

The fingertip control allows the operator to regulate the oil flow with real precision, all the way from « zero » to « full ». The electrical proportional activation of hydraulic functions is simple thanks to a thumbwheel on the joystick. A lot of attention has been paid to an outstanding ergonomoy to improve operator comfort.







# PERFORMANCE

## TRAVEL SPEED

Operating in a closed circuit, the hydrostatic travel drive delivers lots of power while keeping fuel consumption low.

The V80 loader can achieve up to 20km/h on the road. As an option, the V80 is also available in high speed version with a speed from 0 to 36km/h.



## BRAKE INCHING PEDAL

By using the inch brake pedal, fine-tuning of the hydraulic performance is possible. The driver can modify the power between the drive and the working hydraulics. It allows to slow down the loader while keeping the engine rpm up. This feature improves the cycle time of digging and loading operations. This inch brake pedal prevents wheel spin and avoids excessive wear of the tires.

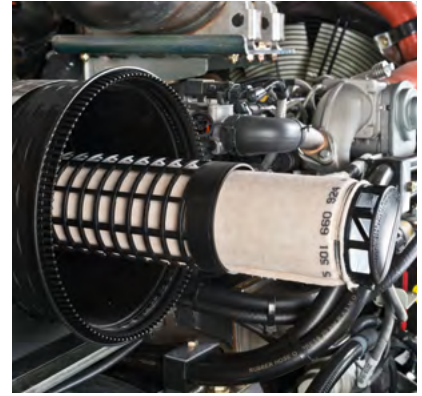
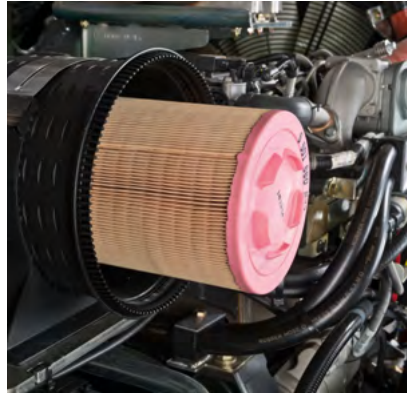

# MAINTENANCE

The large opening offered by the engine hood allows an easy access to all main service items, for an easy and fast maintenance. This contributes to reduce the TCO of the machine. Daily tasks can be performed from ground level to save time.

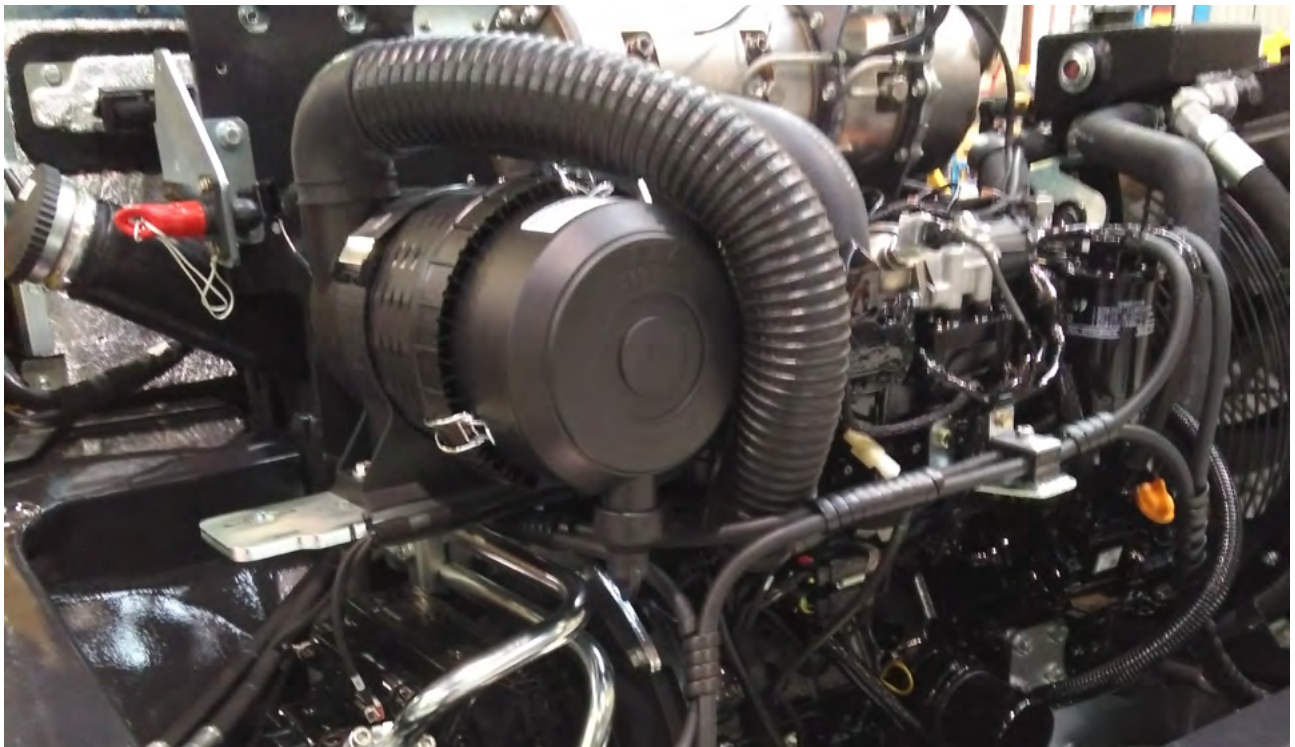

## BATTERY MAIN SWITCH

Can be accessed when standing next to the cab.

## SEPARATE BATTERY POLES

Option : separate battery poles for easy restart thanks to free access under the engine hood.

## CAB CABLING

Simple disconnection of electrical lines when dismantling the cab.





# TAILORED FOR YOUR JOB

In order to provide a wheel loader adapted for the job, Yanmar offers numerous equipment packages and additional equipment. Using equipment tailored to the job helps increase productivity, reduce wear and damage.

## PROTECTION PACKAGE FOR HARSH ENVIRONMENTS

- ▶ Special coating
- ▶ Piston rods for lift, tilt, and steering cylinders with chrome/nickel coating (instead of the standard chrome coating)

## LIFTING ARM

- ▶ Derating dump speed valves

## HYDRAULICS

- ▶ Fourth hydraulic control circuit
- ▶ Biodegradable hydraulic oil
- ▶ Pressure relief valve
- ▶ Hydraulic shock absorbers

## ROAD PERMISSION

The V80 may be driven on the road and can be used with an optional towing hitch as a tractor unit.

## CAB

- ▶ FOPS modification kit (protection against falling objects)
- ▶ Heated external mirror
- ▶ Supplementary diesel heating (independent of engine) with circulation system
- ▶ Sliding window on right-hand side
- ▶ Air conditioning
- ▶ LED working lights rear
- ▶ USB charger

## MAINTENANCE

- ▶ Central lubrication
- ▶ Electric refueling pump

## OPERATION

- ▶ Reverse signal
- ▶ Electronic immobiliser
- ▶ Creeper gear

# DIMENSIONS

## GENERAL-PURPOSE BUCKET

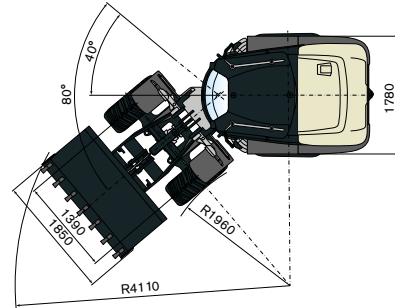
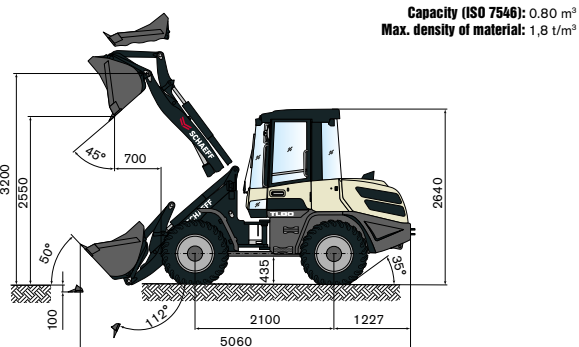

## FORK LIFT ATTACHMENT

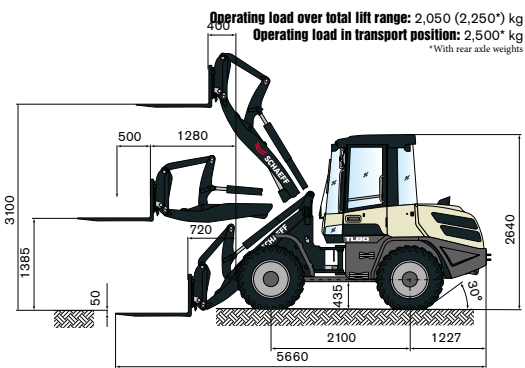

## MULTI-PURPOSE BUCKET

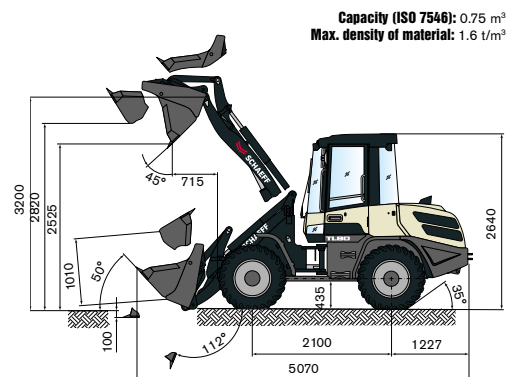

Overall length	5060 mm
Wheelbase	2100 mm
Overall height	2640 mm
Ground clearance	435 mm
Overall width (outside of tires)	1780 mm
Overall width (bucket)	1850 mm
Dumping height (w/o teeth)	2550 mm
Dumping reach (w/o teeth)	700 mm
Max. hinge pin height	3200 mm
Max. lifting height	3070 mm
Digging depth	100 mm
Tilt back angle (at traveling position) Deg.	50°
Dumping angle Deg.	45°
Articulation angle Deg.	40°
Turning radius (track circle)	1960 mm
Turning radius (bucket circle)	4160 mm

## BUCKET TYPE

Bucket Type	Contents	Density	Width	Dump height
General-purpose bucket, quick-attach system (QAS), teeth	0,80 m <sup>3</sup>	1,8 t/m <sup>3</sup>	1850 mm	2550 mm
General-purpose bucket, QAS, bolt-on cutting edge	0,80 m <sup>3</sup>	1,8 t/m <sup>3</sup>	1850 mm	2510 mm
Earth bucket, QAS, teeth	0,90 m <sup>3</sup>	1,6 t/m <sup>3</sup>	1850 mm	2485 mm
Earth bucket, QAS, bolt-on cutting edge	0,90 m <sup>3</sup>	1,6 t/m <sup>3</sup>	1850 mm	2445 mm
Light-material bucket, bolt-on cutting edge	1,00 m <sup>3</sup>	1,2 t/m <sup>3</sup>	1850 mm	2435 mm
Light-material bucket, bolt-on cutting edge	1,20 m <sup>3</sup>	0,8 t/m <sup>3</sup>	1950 mm	2395 mm
Multi-purpose bucket, QAS	0,75 m <sup>3</sup>	1,6 t/m <sup>3</sup>	1850 mm	2525 mm
Multi-purpose bucket, QAS, bolt-on cutting edge	0,75 m <sup>3</sup>	1,6 t/m <sup>3</sup>	1850 mm	2485 mm
Side-dump bucket, QAS, without teeth	0,70 m <sup>3</sup>	1,8 t/m <sup>3</sup>	1850 mm	2450 mm
High-tip bucket, QAS, without teeth	0,70 m <sup>3</sup>	1,2 t/m <sup>3</sup>	1850 mm	3540 mm
Quarry bucket, QAS	0,70 m <sup>3</sup>	1,8 t/m <sup>3</sup>	1850 mm	2530 mm

# SPECIFICATIONS

## STANDARD EQUIPMENT

### ENGINE

Manufacturer, model	Yanmar 4TNV98C
Type	Yanmar diesel engine, exhaust-gas optimised EU Stage V, EPA TIER IV
Guard for fan wheel	
Combustion	4-stroke cycle, Common Rail injection
Number of cylinders	4 in line
Displacement	3 318 cm <sup>3</sup>
Net power rating at 2,200 rpm (ISO 14396)	46,2 kW (63 HP)
Max. torque	241 Nm at 1,430 rpm
Cooling system	Water

### ELECTRICAL SYSTEM

Nominal voltage	12 V
Battery	12 V / 100 Ah / 900 A (DIN-EN50342)
Generator	14 V / 80 A
Starter	12 V / 3,0 kW (4,1 HP)
Cold-starting aid	Glow plugs 12 V
Battery main switch	

### HYDRAULIC SYSTEM

Pump capacity	65 l/min
Working pressure	250 bar
Proportional hydraulic valve four-way control lever (joystick) for the operation of the lift and tilt cylinders with integrated direction-of-travel and speed range button. 3 <sup>rd</sup> additional control circuit <Fingertip control> with continuous operation function provided as standard. Simultaneous, independent control of all movements.	
Hydraulic cylinders : 1 lifting cylinders, 1 tilt cylinder, all dual-action.	
Hydraulically switchable float position by overdriving the pressure point «lower» on the joystick, electrically switchable continuous operation function.	
Single, four-way control lever (joystick) with integrated swing function.	
Controller, direction-of-travel switch and switch for additional control circuit.	

### CABINE

Rubber-mounted full-vision steel cab, ROPS. Optional FOPS (with skylight guard).
Cabine featuring two doors.
Intermittent wipers and washer (front & rear).
Panoramic safety glass.
Sliding window on left-hand side.
Cab heating by engine coolant heat exchanger with 3-speed heater fan.
Windscreen defroster front & rear.
Radio pre-installation.

### LIGHTING

Lighting system in compliance with StVZO and European standards.
Halogen H7 headlamps.
2 working floodlights front.

# SPECIFICATIONS

## UNDERCARRIAGE AND TIRES

Front : rigid planetary final drive axle, centre-mounted disc brake. Limited slip-type differential 35%.

Rear : oscillating planetary final drive axle, with integrated reduction gear, oscillation locking with slewed uppercarriage. Limited slip-type differential 35%.

Angle of oscillation  $\pm 10^\circ$ .

Service brake hydraulically actuated centre-mounted disc brake, acting in all 4 wheels via 4-wheel drive.

Auxiliary brake hydrostatic through closed-circuit travel drive.

Parking brake mechanically actuated centre-mounted disc brake on front axle.

Tires 405/70 R 18 SPT9 Dunlop.

## PERFORMANCE

Travel speed	0 – 20 km/h
Static tipping Load Straight	3770 kg
Static Tipping Load Full Turn	3330 kg
Breakout force (bucket)	45,9 kN
Traction force	42 kN
General purpose bucket (ISO 7546)	0.80 m <sup>3</sup>
Gradability	30°
Noise level	LwA = 101 dB(A) / LpA = 78 dB(A)

## SAFETY

Steering system : articulated steering, fully hydraulic, 1 steering cylinder with final positioning damping on both sides, oil supply via load-sensing priority valve, quick and easy steering even at engine idle-running speed.

Total steering angle 80°

Driver's seat MSG85 with hydraulic suspension, weight adjustable, longitudinal and height adjustment and lap belt in compliance with ISO 7096 & ISO 6683.

Rear-view mirrors foldable.

Self-lock differential 35% in front and rear axle.

Inch brake pedal.

## VIBRATION VALUES IN COMPLIANCE WITH DIRECTIVE 98/37/EEC & EN474

Effective values of acceleration below for entire body	0.5 m/s <sup>2</sup>
And for upper limbs	2.5 m/s <sup>2</sup>

## CAPACITIES

Fuel tank	75 l
Engine oil	8 l
Hydraulic tank	55 l

## MAINTENANCE FREQUENCY

Change engine sump oil	500h
Change engine oil filter	500h
Change engine fuel filter	1 000h
Change hydraulic oil	1 000h
Change cooling fluid	according to demand (at least all 2 years)

## MISCELLANEOUS

Multifunctions display / Smart Control : the driver can adjust the machine exactly to the environment, operation, and individual specific requirements.

# SPECIFICATIONS

## OPTIONAL EQUIPMENT

### ENGINE

Diesel engine with diesel particulate filter (DPF) | High-speed version 36 km/h | Manual throttle for engine rpm with shutdown hydrostatic transmission.

### HYDRAULIC SYSTEM

4th control circuit and installation on lift frame, incl. couplings and continuous operation e. g. for attachments with 2 hydr. functions | Hydraulic outlet for front hand-held hammer, with flow divider | Open return, on lift frame | Pressure relief valve.

### CABINE

FOPS skylight guard | Yellow beacon | Right-hand door with sliding window | Radio installation kit | Working floodlight | LED working lights rear | USB charger.

### CHASSIS AND TIRES

405/70 R 18 EM 01 Mitas | 340/80 R18 TRI2 Nokian | 340/80 R 20 XMCL Michelin | 335/80 R 20 MPT E-70 Conti | 400/70 R 20 IT520 Goodyear | 405/70 R 20 SPT9 Dunlop | 405/70 R 20 EM01 Mitas | 500/45-20 J331 Alliance | Non-standard tires available on request.

### SAFETY

Bucket & loader arm cylinder safety block valve | Descent regulation valve.

### COUPLERS

Ball head coupler | Rockinger trailer coupling.

### MISCELLANEOUS

Central lubrication unit | Special paint | Bio oil | Anti-theft device (immobiliser) | Electrical tank refilling pump | Rear axle weights, approx. 270 kg | Quick couplers (flat face) for 3rd control circuit on lift frame | Back-up alarm for reverse travel | Acceptance as agricultural or forestry tractor | Further optional equipment available on request.



**Yanmar Compact Germany GmbH**  
Kraftwerkstrasse 4  
74564 Crailsheim, Germany  
[www.schaeff-yanmar.com](http://www.schaeff-yanmar.com)